

# Customer Preparation Checklist

## OF H4 MODEL

# Unloading devices

## Forklift 10t or Crane



Crowbar (Option)

## Pallet jack



## Electric drill and bits



## Environmental requirements

1

- Temperature: 0-40°C

2

- The foundation should be concreted ground thickness over 100mm.and be leveled.

3

- Rainproof workshop、 enough space for machine

## Specification for Unloading Evidence Retained on Customer Site



Double click

**The customer or distributor must strictly follow the pre-arrival preparation to carry out the operation, unloading to take photos and video, for evidence. We have the corresponding normative documents, please strictly implement.**

## power and current of the machine

Model	6kw		12kw		15kw		20kw		30kw		40kw	
	power (kw)	Current (A)	power (kw)	Current (A)	power (kw)	Current (A)	power (kw)	Current (A)	power (kw)	Current (A)	power (kw)	Current (A)
H4	46.9	89	72.5	138	94	178.5	109.5	208	145.5	276.3	184.5	350
Optional1	XV22/16Q		XV37/16Q		Optional2	5.5KW		7.5KW		11KW		
	power (kw)	Current (A)	power (kw)	Current (A)		power (kw)	Current (A)	power (kw)	Current (A)	power (kw)	Current (A)	
Aircompressor	22	42	37	70	Dust Collector	5.5KW	12	7.5	16	11	21	

Note: The current is calculated based on 380V voltage

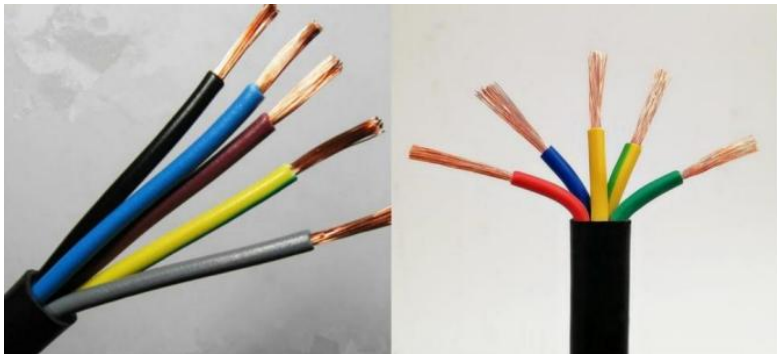

### Power supply requirements

Five cores, copper wire. Phases L1、L2、L3、Neutral N、PE

Good grounding point (Reliable grounding cable)

# Power preparation requirements

Schematic diagram of circuit connection

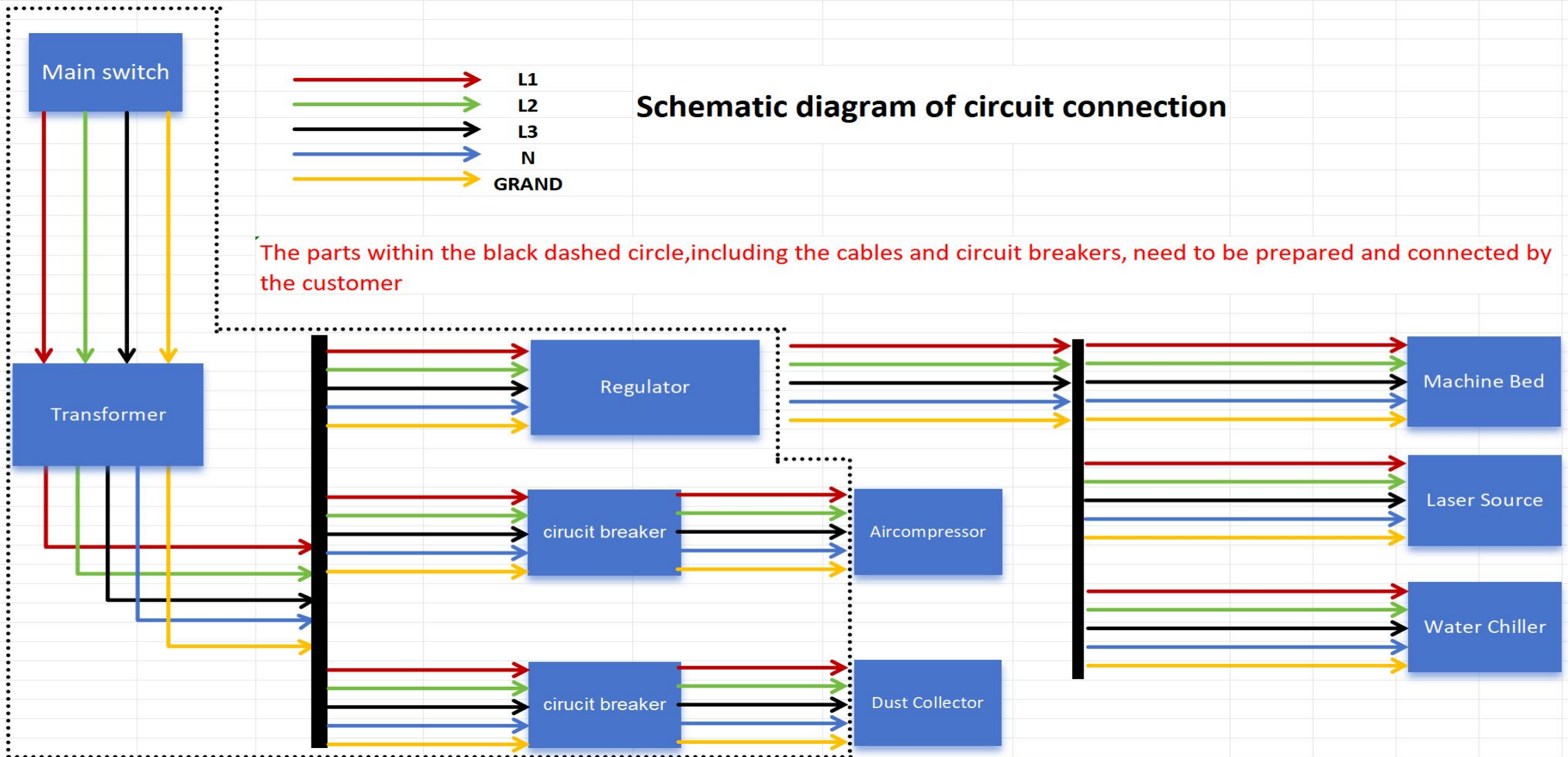

## Oxygen gauge



Specifaction: Oxygen purity  $\geq 99.9\%$ , outlet pressure must reach 1.0Mpa, and concentration  $< 100\text{ppm}$

## Nitrogen gauge



Specifaction: The flow rate is greater than 2 cubic meters per minute, the purity is 99.99%, and the outlet pressure is 2.5Mpa

Specification: Adapt to local clyliner

## Gas Supply

### Customer Preparation

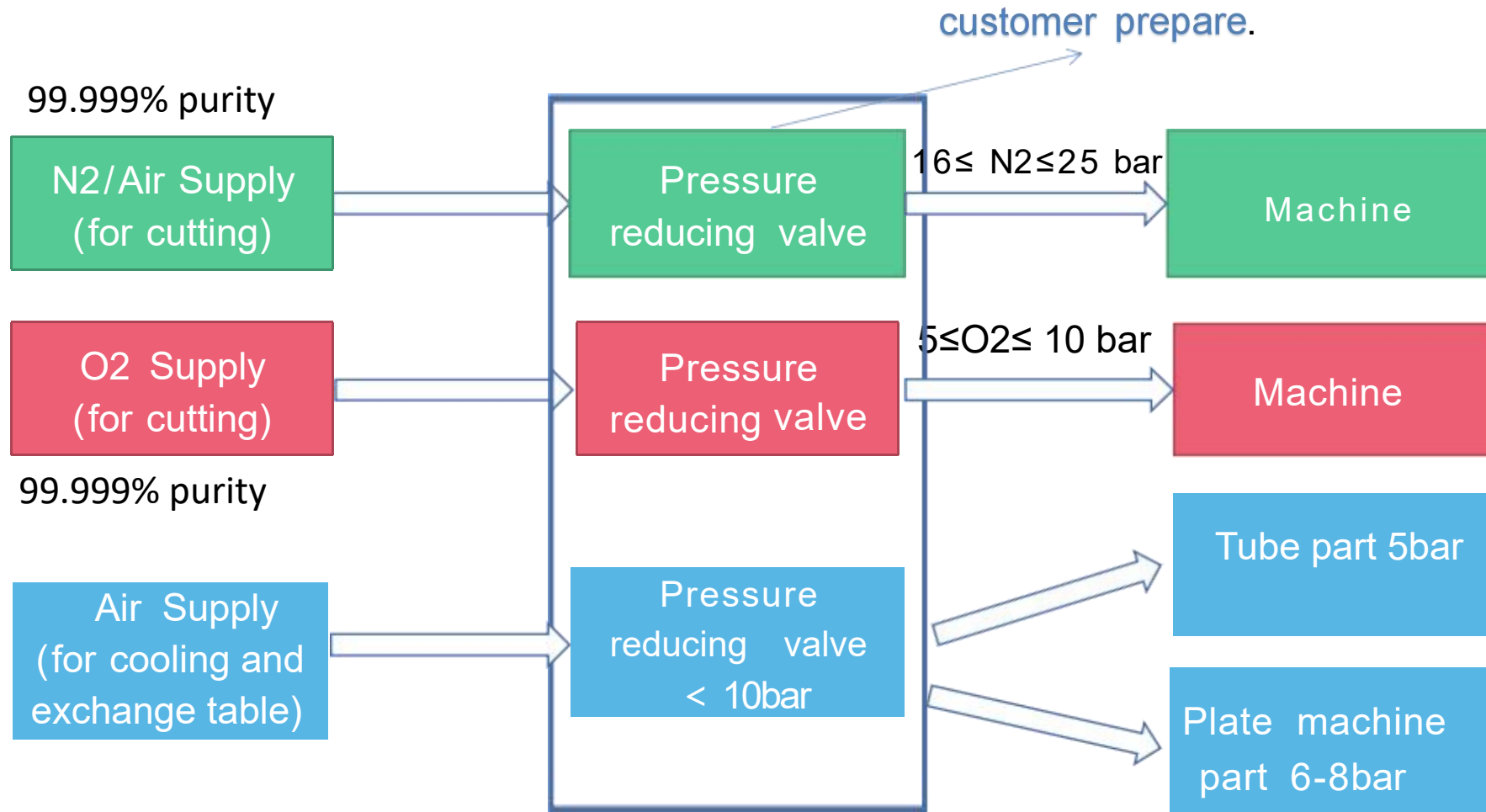

### Auxiliary gas

## Cooling water preparation

Model	HL-6000-QG2/2	HL-12000-QG2/2	HL-15000-QG2/2	HL-20000-QG2/2	HL-30000-QG2/2	HL-40000-QG2/2
liters	60	150	200	275	300	400

**Purified water, distilled water or deionized water.  
Should be Changed every 1~2 month.**

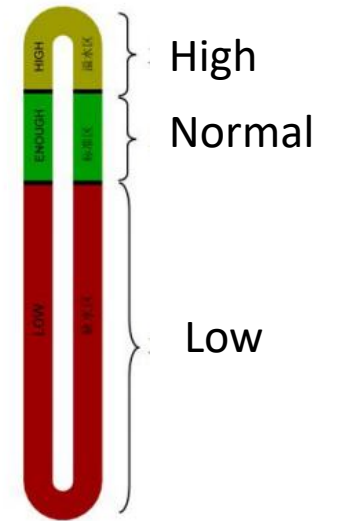

## Preparation of cutting test materials

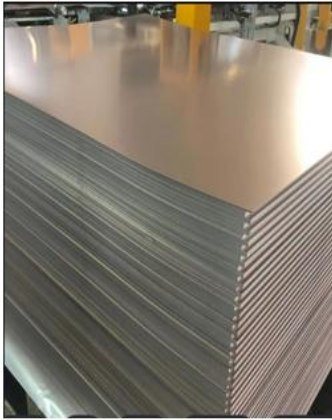

Stainless steel

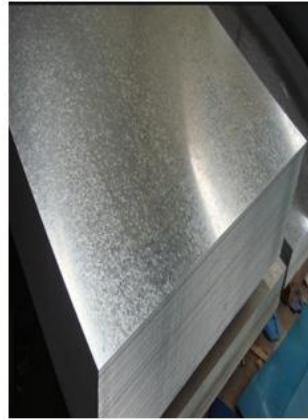

Galvanized



Carbon steel



Aluminum

Please prepare metal sheets that you often cut, such as carbon steel (cs) stainless steel (ss), Al, Brass.etc. it should be clean and not rusty.

Customer prepare test  
Material

Customers need to be prepared in advance, machine learning operators, follow the engineers to learn. From software operation, system use, maintenance and other knowledge.

We recommend that at least two learners take part in this work。

Machine learning operator



**SENFENG**

切割 | 折弯 | 焊接 | 熔覆 | 自动化

匠/心/森/峰 智/造/未/来

**Please inform us after all pre-installation preparations are complete.**

**We will then arrange for an engineer to arrive at your factory and begin installation as soon as possible.**

**Please note that we will not dispatch the engineer until these preparations are complete.**

**Thank you for your understanding and support**

# SENFENG

切割 | 折弯 | 焊接 | 熔覆 | 自动化

匠心森峰 智造未来

INGENUITY INTELLIGENCE CREATE THE FUTURE